

Warping Instructions

With your Mama Bear™ or Papa Bear™ models of Handcrafted Yarn Swift™ you can do warping. If you are a weaver, this will be very handy, especially if you travel or would like to do this in different places. Your swift becomes a portable warping board.

The following are instructions to perform warping for a 2.5 yard warp. Longer warps can be accomplished with 4-6 additional pegs.

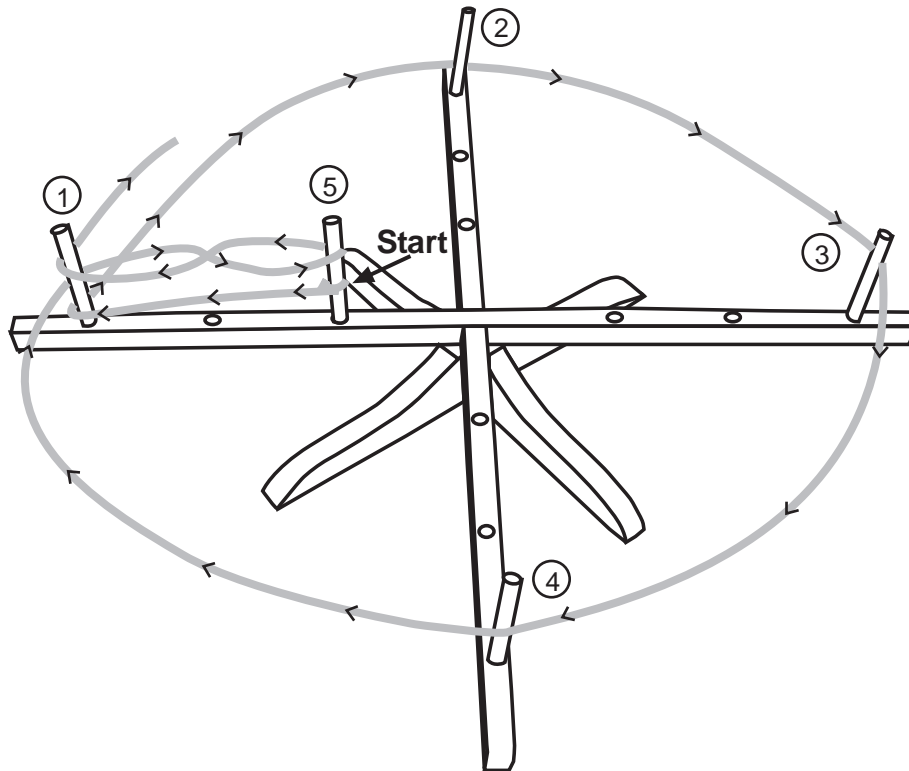

1. Place one peg in each of the farthest out holes at the end of each of the four arms (#1-4 see illustration).
2. Place one peg in a hole closest to the center (#5 see illustration).
3. Tie or wrap the end of your yarn on peg #5.
4. Your cross will be made between pegs #5 and #1 as illustrated in the diagram.
5. Starting at peg #5, go around peg #1, #2, #3, #4, around the outside of #1, cross and go all around #5, cross, go around #1 and on to #2, to make your second and third and etc., warp.
6. Repeat for as many times as desired.
7. When the desired number of warps have been wound around the swift, return to peg #5. Tie up the yarn at peg #5 and cut the yarn against the #5 peg on the side of the peg closest to the center of the arms. This will give you a warp of 2.5 yards for each strand you wrapped round the swift.